

Thermoweld Acrylic

Industrial Skylight



Acrylic Dome

Model AS

Frame Material: Fiberglass
IECC 2015: Meets with controls all climate zones
OSHA: Meets CFR fall regulations
AAMA: WDMA/CSA 101/I.S.2/A440-08 & WDMA/CSA 101/I.S.2/A440-05

Details:

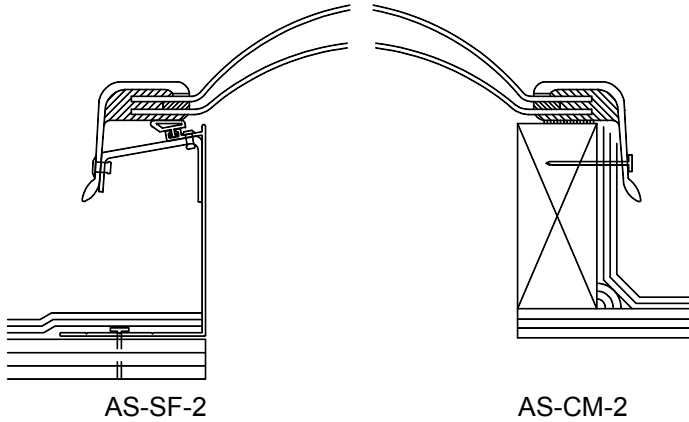

Specifications:

Thermoweld skylight shall be model No. _____ as manufactured by Bristolite Daylighting Systems, Santa Ana, CA. Skylights shall be fully factory assembled consisting of an acrylic dome with a CC-2 classification that shall be fused to its own counter flashing fiberglass skirt through the Thermoweld process. The fiberglass skirt fasteners are to be corrosive resistant. The skylight frame shall be installed either on a 1-1/2" wide curb furnished by others or on its own 4", 9", or 12" high self flashing curb fabricated from aluminum with a 2-3/4" roof nailing flange.

Sizes:

Model Number	Inside Curb Dimension	Model Number	Inside Curb Dimension	Model Number	Inside Curb Dimension	Model Number	Inside Curb Dimension
1414-AL	14 1/4" x 14 1/4"	6060-AL*	60" x 60"	2272-AL	22 1/4" x 72"	3746-AL	37" x 46 1/4"
1919-AL	19" x 19"	7070-AL*	70 1/4" x 70 1/4"	2296-AL	22 1/4" x 96"	3775-AL	37" x 75"
2222-AL	22 1/4" x 22 1/4"	7575-AL*	75" x 75"	2496-AL	24" x 96"	3859-AL	38" x 59"
3030-AL	30 1/4" x 30 1/4"	8484-AL*	84" x 84"	3037-AL	30 1/4" x 37"	4669-AL	46 1/4" x 69 1/2"
3737-AL	37" x 37"	9292-AL*	92 1/2" x 92 1/2"	3046-AL	30 1/4" x 46 1/4"	4689-AL	46 1/4" x 89 1/2"
4242-AL	42" x 42"			3069-AL	30 1/4" x 69 1/2"	4896-AL	48" x 96"
4646-AL	46 1/4" x 46 1/4"	1422-AS	14 1/4" x 22 1/4"	3096-AL	30 1/4" x 96"	5460-AL*	54" x 60"
4848-AL	48" x 48"	1446-AS	14 1/4" x 46 1/4"	3496-AL	34" x 96"	6072-AL*	60" x 72"
5555-AL*	55" x 55"	2230-AS	22 1/4" x 30 1/4"	3696-AL	36" x 96"		Call for additional sizes

*Sizes are **only** available in the following acrylic colors: WTM, CC, BT or GT.

Solar Heat Gain Coefficient = .50, U Factor = .56, Visible Light Transmission = 53% (Typical for CM double glazed units)

Features:

1. Curb Mounted (**CM**) or Self Flashing (**SF**)
2. Five Acrylic Color Choices: High White (**WTH**), Medium White (**WTM**), Bronze (**BT**), Grey (**GT**) or Clear (**CC**)
3. Standard Bronze Color Fiberglass Frame Finish
Add highlighted suffixes to model number where applicable:
i.e. **3030-AS-CM-2-WTM-CC**

Options:

1. Insulating Double Domes (**2**) or Single Dome (**1**)
2. Pyramid (**P**) or Double Hip (**DH**) Shaped Dome (selected sizes)
3. Low Profile Dome (**LP**) (selected sizes)
4. Base Frame Finish - (self flashing only) – Bronze Anodize (**BA**), Clear Anodize (**CA**), White Painted (**WP**) or Mill Finish (**MF**)
5. Fiberglass Frame Finish – White Gel (**WGEL**)
6. Self Flashing Bases of 9" or 12" (**9** or **12**)

Options: (cont.)

7. EPDM Curb Seal Tape (**CMT**)
8. Insulated Frame (**INS**) (Self flashing only)
9. Double Wall (**DW**) (Self flashing only)
10. Wood Nailer (**WN**) (Self flashing only)

Accessories: See PDS (Product Data Sheets) for these Items

1. Gladiator
 - a. Structural Curb (**SC**)
 - b. Security Grills (**SG**)
 - c. Safety Screens (**SSCRN**)
2. Quickkit (Installation Kits)
 - a. Stainless Steel (**QKSS**)
 - b. Zinc Plated (**QKZP**)