



Not to be distributed outside of FM Approvals and its affiliates except by Customer

APPROVAL REPORT

APPROVAL OF TUFFLITE TRIARCH MODEL ALT-CM-1-PC AND TUFFLITE TRIARCH MODEL ALT-CM-2-CPC SKYLIGHTS PER FM APPROVAL STANDARD 4431 – SKYLIGHTS

Prepared for:

**Bristol Fiberlite Industries Inc
dba Bristolite® Skylights
401 E Goetz Ave
Santa Ana, CA 92707
United States**

Project ID: 3044352

Class: 4431

Date of Approval: 11/26/2012

Authorized by:

Cynthia E. Frank, AVP, Group Manager,
Materials

FM Approvals
1151 Boston Providence Turnpike
P.O. Box 9102
Norwood, MA 02062

**APPROVAL OF TUFFLITE TRIARCH MODEL ALT-CM-1-PC AND TUFFLITE
TRIARCH MODEL ALT-CM-2-CPC SKYLIGHTS PER
FM APPROVAL STANDARD 4431 – SKYLIGHTS**

from

**Bristol Fiberlite Industries Inc
dba Bristolite® Skylights
401 E Goetz Ave
Santa Ana, CA 92707
United States**

I INTRODUCTION

- 1.1 Bristolite® Skylights submitted their TUFFLITE TRIARCH Model ALT-CM-1-PC and Model ALT-CM-2-CPC skylights to determine if they meet the Approval requirements of the Standard listed below for skylights. Bristolite® Skylights examined in this report are of an aluminum frame construction with polycarbonate and acrylic domed lenses.
- 1.2 This report may be reproduced only in its entirety and without modification.
- 1.3 **Standard:**

Title	Class Number	Date
Approval Standard for Skylights	4431	September, 2006

- 1.4 Examination included Spread of Flame Test for Skylights from an Exterior Ignition Source, Simulated Hail Resistance Test Using Freezer Ice Balls and UV Testing, Simulated Impact Tests for Skylights and Simulated Wind Uplift Resistance Test for Skylights.
- 1.5 As a fabricator of an Approved product, the Bristolite® Skylights facility is audited on a regular basis to determine that sufficient quality controls are being used to assure continued production equivalent to that originally Approved.
- 1.6 Tests show that the Bristolite® Skylights TUFFLITE TRIARCH Model ALT-CM-1-PC and Model ALT-CM-2-CPC skylights meet the Approval requirements of the **Standard** listed above for skylights.
- 1.7 **Listings:** The product will be listed in the Approval Guide, an online resource of FM Approvals.

II DESCRIPTION

Bristolite® Skylights TUFFLITE TRIARCH Model ALT-CM-1-PC and Model ALT-CM-2-CPC skylights are available in sizes up to 4 ft (1.2 m) by 8 ft (2.4 m) and 5 ft (1.5 m) by 6 ft (1.8 m). The skylights are produced with a Type 6063-T6 aluminum frame that is secured to a 1.5 in. (38 mm) thick wood curb and are available in single dome (Model ALT-CM-1-PC) or double dome (Model ALT-CM-2-CPC) units. Model ALT-CM-1-PC skylights are fabricated with single domed lenses formed out of minimum 0.118 in. (3.0 mm) thick polycarbonate sheet material and

FM APPROVALS
Project ID: 3044352

Model ALT-CM-2-CPC skylights are fabricated with an additional inner dome formed out of minimum 0.098 in. (2.5 mm) thick clear acrylic sheet material.

III EXAMINATIONS AND TESTS

3.1 Samples were submitted for examination and testing as follows:

3.1.1 Tests conducted were as required by the **Standard** listed in paragraph 1.3 above.

3.1.2 Production of the Bristolite® Skylights TUFFLITE Model ALT-CM-1-PC and Model ALT-CM-2-CPC skylight samples were witnessed by a representative of FM Approvals on February 15, 2012 at the Bristolite® Skylights production facility in Santa Ana, California, USA. All data is on file at FM Approvals under Project ID 3044352 along with other documents and correspondence applicable to this program.

3.2 Spread of Flame Tests from an Exterior Ignition Source

3.2.1 The fire tests from an exterior ignition source were conducted in accordance with a modified version of ASTM E108 Spread of Flame Tests, as documented in the Approval Standard referenced in section 1.3. Testing was completed using the FM Approvals ASTM E108 Spread of Flame Test Apparatus.

3.2.1.1 The wind velocity over the top of the standard panel was adjusted to 12 ± 0.5 mph (5.3 ± 0.2 m/s).

3.2.1.2 Flame exposure: The flame was adjusted to $1400 \pm 50^\circ\text{F}$ ($760 \pm 28^\circ\text{C}$) for Class A. The flame temperature was measured by a thermocouple located 1 in. (25.4 mm) above the surface of the standard panel and 1/2 in. (13 mm) toward the flame source from the lower edge of the standard panel. The flame was applied to each test panel for 10 minutes.

3.2.1.3 During and after the application of the flame, each panel was observed for the distance of maximum flame spread, flaming of melting particles and other damage.

3.2.2 Two test samples were prepared. The components and sequence of installation were as follows:

Samples 1 and 2: Bristolite® Skylights TUFFLITE Model 4896 ALT-CM-1-PC (single skin) skylight measuring 4 ft (1.2 m) by 8 ft (2.4 m) with 0.118 in. (3.0 mm) thick polycarbonate dome, secured to a metal test frame

Samples 3: Bristolite® Skylights TUFFLITE Model 4896 ALT-CM-2-CPC (double skin) skylight measuring 4 ft (1.2 m) by 8 ft (2.4 m) with 0.118 in. (3.0 mm) thick polycarbonate outer dome and 0.098 in. (2.5 mm) thick inner acrylic dome, secured to a metal test frame

3.2.3 The results of the Spread of Flame Tests from an Exterior Ignition Source were as follows:

Sample No.	Slope	Maximum Flame Spread	Rating
1	1 in 12	No Ignition	Class A

FM APPROVALS
Project ID: 3044352

2	1 in 12	No Ignition	Class A
3	1 in 12	No Ignition	Class A

Melting and sagging of the samples was observed. The melted material was not glowing or flaming nor did it come in contact with the floor. The samples were permanently deformed during testing.

3.3 Simulated Hail Resistance Tests Using Freezer Ice Balls

3.3.1 Tests were conducted using the FM Approvals Freezer Ice Ball Simulated Hail Damage Test Apparatus to evaluate the ability of the skylight glazing materials to withstand a hailstorm without developing any through openings.

3.3.1.1 Two samples of the test material were submitted for testing. The first sample of the material was designated as Sample A and was conditioned at 40°F ±5°F (4°C ±3°C) for a period of not less than 48 hours immediately prior to the test.

3.3.1.2 The second sample of the material was designated as Sample B and was conditioned (weathered) for 1000 hours in the FM Approvals Ultraviolet Weatherometer prior to conditioning at 40°F ±5°F (4°C ±3°C) for a period of not less than 48 hours immediately prior to the test.

3.3.1.3 Each sample was tested within five (5) minutes of being removed from the 40°F ±5°F (4°C ±3°C) conditioning box.

3.3.2 For the severe hail damage tests, a 2.0 in. (51 mm) diameter frozen ice ball with a nominal weight of 0.1385 lbs (62.9 g), +10/-0% was projected at each test sample at a nominal speed of 76.1 mph, +10/-0% in order to impact the sample with a nominal kinetic energy of 26.8 ft-lbs (36.4 J), +10/-0%. This procedure was repeated 10 times within a 12 in. (305 mm) diameter location on each of the test samples. After each impact the sample was inspected for any through openings.

3.3.3 Two 13 in. x 13 in. (330 mm x 330 mm) samples were prepared. The results were as follows:

<u>Sample ID</u>	<u>Sample Material</u>	<u>Result</u>
A	0.118 in. (3.0 mm) thick Polycarbonate Dome Material	Pass
B	0.118 in. (3.0 mm) thick Polycarbonate Dome Material	Pass

3.4 FM Approvals Simulated Impact Tests

3.4.1 Tests were conducted using the FM Approvals Simulated Impact Test Apparatus to evaluate the ability of the skylight to resist simulated impacts without damage.

3.4.1.1 A cylindrical canvas bag impactor with a diameter of 12 in. (305 mm) and filled with dry sand to a total assembly weight of 100 lbs (45.5 kg) ± 4 oz. (113.4 g) was dropped from a height of 4 ft (1.2 m) above the highest surface of the test panel.

3.4.1.2 The profile being considered for Approval was subjected to two (2) separate impacts from the impactor. The first impact was located within a 12 in. (305 mm) diameter circle located at the test specimen's center point. The second impact was located within 12 in. (305 mm) from the end support.

FM APPROVALS
Project ID: 3044352

3.4.1.3 There must be no through openings through which a 4 in. (102 mm) diameter sphere can pass. The dome shall not become dislodged from the curb or drop out.

3.4.2 One sample, with the largest dome area for which Approval is sought, was prepared.

Sample: Bristolite® Skylights TUFFLITE Model 4896 ALT-CM-1-PC measuring 4 ft (1.2 m) by 8 ft (2.4 m), with 0.118 in. (3.0 mm) thick single skin Polycarbonate dome.

Result: No damage to the sample was observed after either impact.

3.5 FM Approvals 5 by 9 ft (1.5 by 2.7 m) Simulated Wind Uplift Pressure Test

3.5.1 The test was conducted using the FM Approvals Uplift Pressure Test Apparatus to evaluate the ability of the skylight to resist a minimum simulated wind uplift pressure of 60 psf (2.9 kPa) without failure of the assembly.

3.5.1.1 The simulated wind uplift pressure test utilized a 5 ft. (1.5 m) long by 9 ft. (2.7 m) wide by 2 in. (51 mm) deep steel pressure vessel arranged to apply air pressure at pre-established standard rates to the underside of the test sample which formed the top of the pressure vessel. The vessel was pressurized with compressed air.

3.5.1.2 A net pressure of 30 psf (1.4 kPa) was applied to the test sample and maintained for 1 minute. The pressure was increased to 45 psf (2.2 kPa), then to 60 psf (2.9 kPa) and held for 1 minute at each increment. The pressure was increased in increments of 15 psf (0.7 kPa) every minute until failure occurred.

3.5.2 One 5 by 9 ft. (1.5 by 2.7 m) test sample was prepared. The components, sequence of installation and test result are as follows:

Sample No: Polyethylene sheet, 6 mil (0.006 in., 0.25 mm) thickness, loose laid over the FM Approvals Wind Uplift Frame.
Bristolite® Skylights TUFFLITE Model 4896 ALT-CM-1-PC measuring 4 ft (1.2 m) by 8 ft (2.4 m) with aluminum frame secured to minimum 1.5 in. (38 mm) thick wood curb framing with #10 self tapping stainless steel screws secured through all four sides of the aluminum frame and spaced maximum 6 in. o.c. (152 mm).

Result: The sample withstood a pressure of 150 psf (7.2 kPa) for 1 minute as required by the test standard and meets the criteria for a rating of 150 psf (7.2 kPa). The sample failed during the incremental pressure increase to 165 psf (7.9 kPa) due to fastener withdrawal from the aluminum frame material.

IV MARKING

4.1 The manufacturer shall mark each skylight unit with the manufacturer's name and product trade name. In addition, the skylight unit must be marked with the Approval Mark of FM Approvals.

4.2 Markings denoting Approval by FM Approvals shall be applied by the manufacturer only within

FM APPROVALS
Project ID: 3044352

and on the premises of manufacturing locations that are under the FM Approvals Facilities and Procedures Audit program.

- 4.3 The manufacturer agrees that use of the FM Approvals name or Approval Mark is subject to the conditions and limitations of the Approval by FM Approvals. Such conditions and limitations must be included in all references to Approval by FM Approvals.

V FACILITIES AND PROCEDURES AUDITS

The Bristolite® Skylights manufacturing location in Santa Ana, California is subject to periodic audit inspections to determine that the quality and uniformity of the materials have been maintained and will provide the same level of performance as originally FM Approved. The facilities and quality control procedures in place have been found to be satisfactory to manufacture product identical to that examined and tested as described in this report.

VI MANUFACTURER'S RESPONSIBILITIES

- 6.1 To assure compliance with his procedures in the field, the manufacturer shall supply to the roofer such necessary instruction or assistance required to produce the desired performance achieved in the tests.
- 6.2 The manufacturer shall notify FM Approvals of any planned change in the FM Approved product, prior to general sale or distribution, using Form 797, FM Approved Product Revision Report.

VII DOCUMENTATION

The following document describes the product and is used for conducting follow-up audits.

Document	Issue	Description
Bristolite® Skylights TUFFLITE TRIARCH Model ALT-CM-1-PC and Model ALT-CM-2-CPC Skylights	November, 2012	Facilities and Procedures Audit Manual

VIII CONCLUSIONS

- 8.1 The test results from this program indicate that Bristolite® Skylights TUFFLITE TRIARCH Model ALT-CM-1-PC and Model ALT-CM-2-CPC skylights meet the requirements of FM Approvals Standard 4431, Approval Standard for Skylight as indicated below.
- 8.1.2 Bristolite® Skylights TUFFLITE TRIARCH Model ALT-CM-1-PC and Model ALT-CM-2-CPC skylights are provided in sizes 4 ft (1.2 m) by 8 ft (2.4 m) and 5 ft (1.5 m) by 6 ft (1.8 m). Model ALT-CM-1-PC skylights are fabricated with single domed lenses formed out of minimum 0.118 in. (3.0 mm) thick polycarbonate sheet material. Model ALT-CM-2-CPC skylights are fabricated with an additional inner dome formed out of minimum 0.098 in. (2.5 mm) thick clear acrylic sheet material.

FM APPROVALS
Project ID: 3044352

- 8.2 Bristolite® Skylights TUFFLITE TRIARCH Model ALT-CM-1-PC and Model ALT-CM-2-CPC skylights described above meet the FM Approvals requirements for a 150 psf (7.2 kPa) wind uplift rating when secured to minimum 1.5 in. (38 mm) thick wood curb framing, with #10 self tapping stainless steel screws. Fasteners are secured through all four sides of the aluminum frame and spaced maximum 6 in. o.c. (152 mm).
- 8.3 Bristolite® Skylights TUFFLITE TRIARCH Model ALT-CM-1-PC and Model ALT-CM-2-CPC skylights meet the FM Approvals requirements for a Severe Hail (SH) rating as tested with 2.0 in. (51 mm) diameter frozen ice balls.
- 8.4 Bristolite® Skylights TUFFLITE TRIARCH Model ALT-CM-1-PC and Model ALT-CM-2-CPC skylights meet the criteria for a Spread of Flame Fire rating of Class A at a maximum slope of 1 in 12.
- 8.4.1 Fire tests indicate that if a sprinkler is installed directly under a TUFFLITE TRIARCH Model ALT-CM-1-PC and Model ALT-CM-2-CPC skylight, steps shall be taken to prevent the skylight from interfering with the sprinkler's operation.
- 8.5 Since an authorized Master Agreement exists, Approval is effective as of the date of this report.
- 8.6 Once Approval is effective, the above skylights will be listed in the Approval Guide, an online resource of FM Approvals.

TESTING SUPERVISED BY:

M. P. DeSousa

PROJECT DATA RECORD:

Project I.D. # 3044352

ORIGINAL TEST DATA:

PDR for Project I.D. # 3044352

ATTACHMENTS:

Appendix A (1 page), Appendix B (1 page)

REPORT BY:



Michael P. DeSousa
Engineer - Materials Group

REPORT REVIEWED BY:



Jill E. Norcott, PE
Technical Team Manager - Materials Group

Appendix A

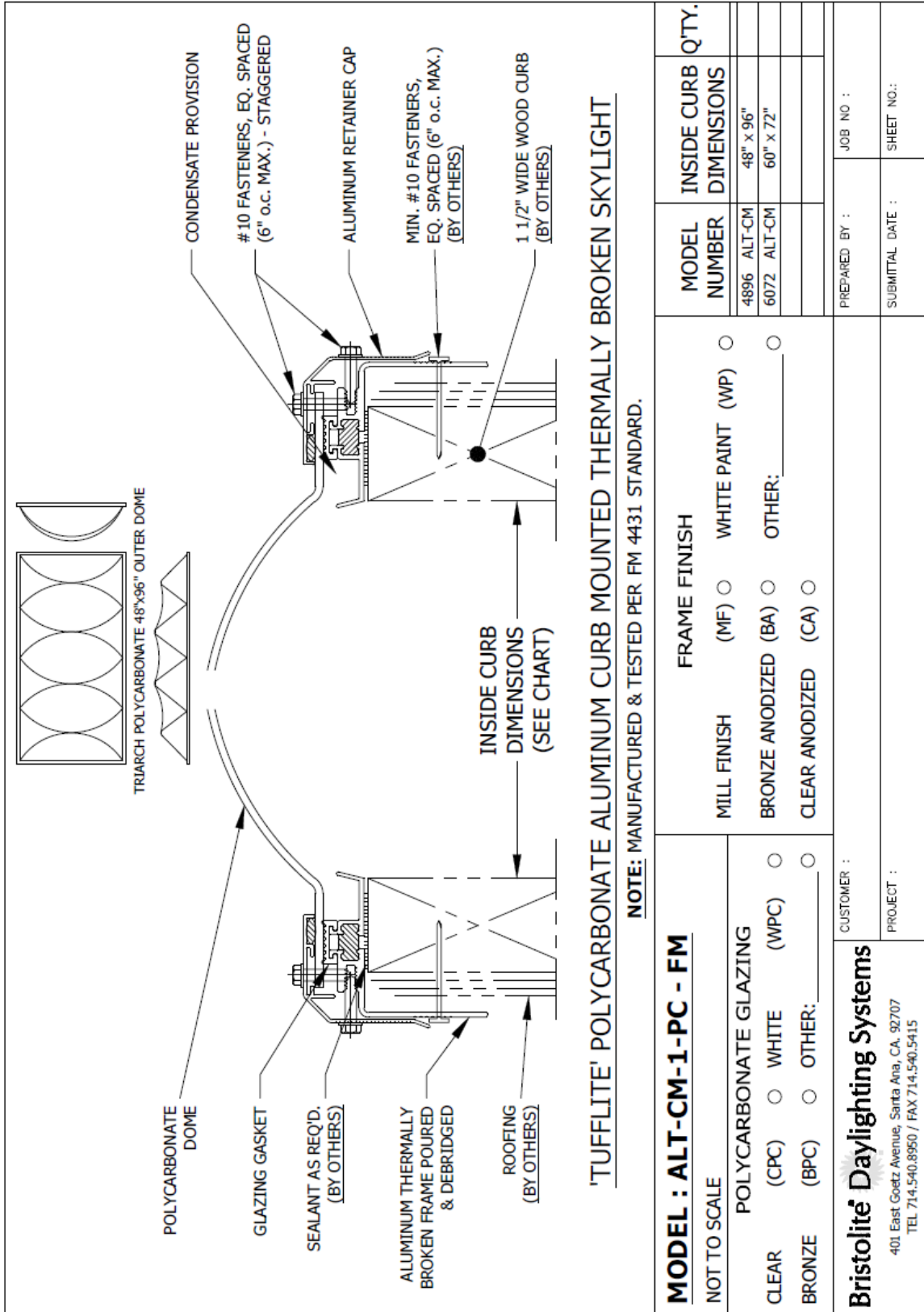

'TUFFLITE' POLYCARBONATE ALUMINUM CURB MOUNTED THERMALLY BROKEN SKYLIGHT

NOTE: MANUFACTURED & TESTED PER FM 4431 STANDARD.

MODEL : ALT-CM-1-PC - FM		FRAME FINISH		MODEL NUMBER		INSIDE CURB Q'TY. DIMENSIONS	
NOT TO SCALE		MILL FINISH (MF) <input type="radio"/>	WHITE PAINT (WP) <input type="radio"/>	4896	ALT-CM	48" x 96"	
CLEAR (CPC) <input type="radio"/>	WHITE (WPC) <input type="radio"/>	BRONZE ANODIZED (BA) <input type="radio"/>	OTHER: _____ <input type="radio"/>	6072	ALT-CM	60" x 72"	
BRONZE (BPC) <input type="radio"/>	OTHER: _____ <input type="radio"/>	CLEAR ANODIZED (CA) <input type="radio"/>					
Bristolite Daylighting Systems		CUSTOMER :		PREPARED BY :		JOB NO :	
401 East Goetz Avenue, Santa Ana, CA. 92707 TEL 714.540.8950 / FAX 714.540.5415		PROJECT :		SUBMITTAL DATE :		SHEET NO.:	

DWG. LOCATION: X:\ASHARED\ENGR\DEPT\ACAD DRAWINGS\submit\Bristol\Resident\ALT\ALT-CM-1-PC - FM / Rpvlik - 10/1/2012

Appendix B

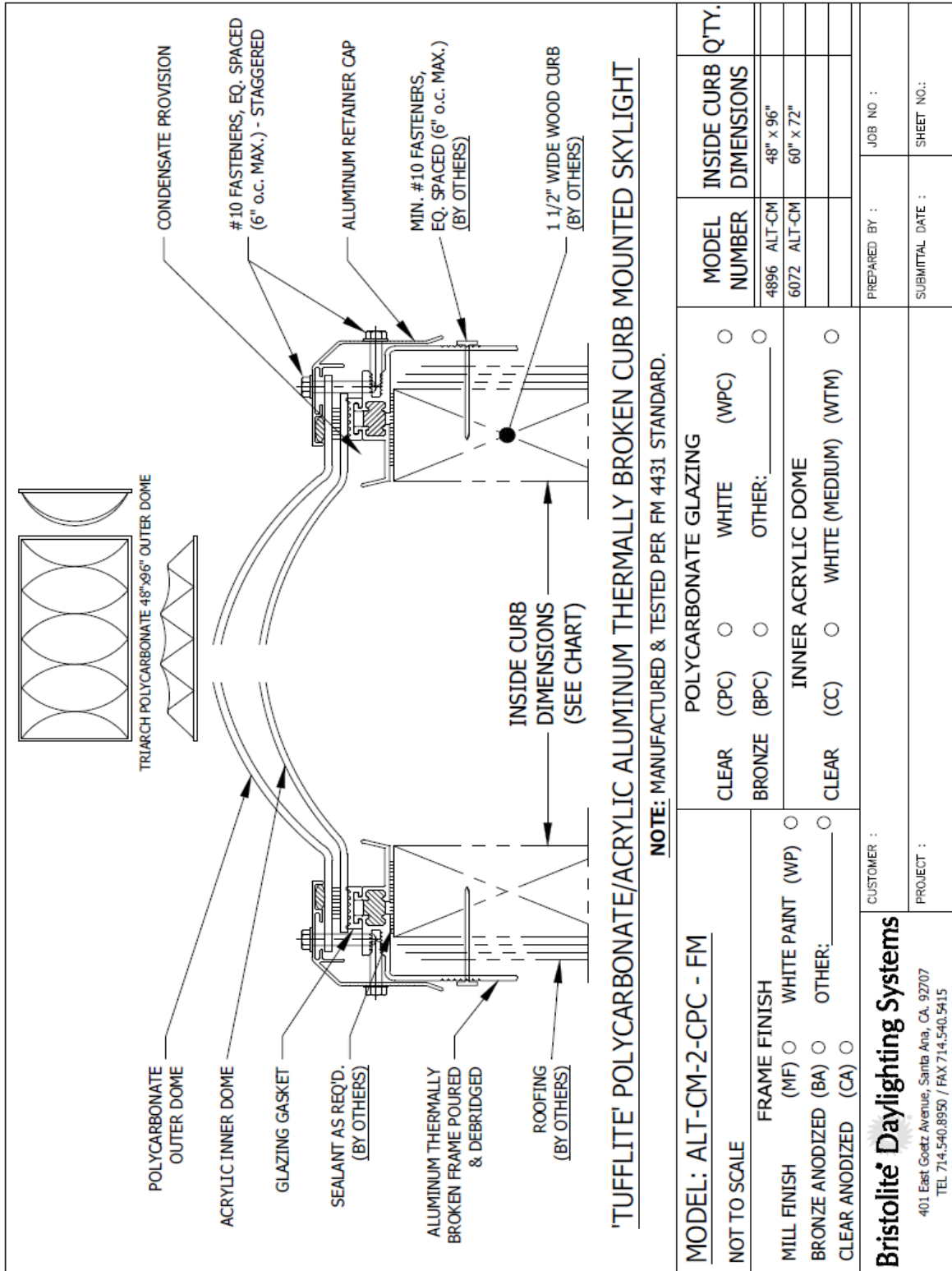

'TUFLITE' POLYCARBONATE/ACRYLIC ALUMINUM THERMALLY BROKEN CURB MOUNTED SKYLIGHT

NOTE: MANUFACTURED & TESTED PER FM 4431 STANDARD.

MODEL: ALT-CM-2-CPC - FM		POLYCARBONATE GLAZING		MODEL NUMBER	INSIDE CURB Q'TY.
NOT TO SCALE		CLEAR (CPC) <input type="radio"/>	WHITE (WPC) <input type="radio"/>	4896 ALT-CM	48" x 96"
MILL FINISH		BRONZE (BPC) <input type="radio"/>	OTHER: _____ <input type="radio"/>	6072 ALT-CM	60" x 72"
FRAME FINISH		INNER ACRYLIC DOME			
(MF) <input type="radio"/>	WHITE PAINT (WP) <input type="radio"/>	CLEAR (CC) <input type="radio"/>	WHITE (MEDIUM) (WTM) <input type="radio"/>		
BRONZE ANODIZED (BA) <input type="radio"/>	OTHER: _____ <input type="radio"/>				
CLEAR ANODIZED (CA) <input type="radio"/>					
CUSTOMER :		PREPARED BY :		JOB NO. :	
PROJECT :		SUBMITTAL DATE :		SHEET NO.:	

Bristolite Daylighting Systems
401 East Goetz Avenue, Santa Ana, CA, 92707
TEL 714.540.8950 / FAX 714.540.5415

DWG. LOCATION: X:\ASHARED\ENGR\DEPT\ACAD DRAWINGS\Submit\Bristol\Resident\ALT-CM-2-CPC - FM / Rpavlik - 10/1/2012